

VIRGINIA
SHIPBUILDING CARRIER AND
INTEGRATION CENTER
ADVANCED

ALYSON LARIMER
LIGHTING/ELECTRICAL
AE FACULTY CONSULTANT:
DR. RICK MISTRICK
JANUARY 19, 2011
REVISED LIGHTING PROPOSAL

Table of Contents

Executive Summary.....	2
Background	3
Figure 1: Floor plan and photo of Lobby/Atrium Space	3
Figure 2: Second through sixth floor open office floor plan	4
Figure 3: Auditorium floor plan	4
Figure 4: Exterior gathering space proposed design site.....	5
Lighting Depth.....	5
Overview	5
Lobby/Atrium.....	5
Open Office Work Space	6
Auditorium	6
Exterior Gathering Space	6
Designer Comments from Lutron Presentations (08 December 2010)	7
Electrical Depth.....	10
Re-Design of Four Spaces.....	10
Lobby/Atrium Ground Floor.....	10
Open Office Work Space Floors 2-6	10
Auditorium Second Floor Laboratory Wing	10
Exterior Gathering Space Site behind Office Tower.....	11
Protective Device Coordination Study and Short Circuit Analysis	11
Depth Topic 1 Bus Duct vs. Conduit and Wires.....	11
Depth Topic 2 Motor Control Center Design	11
Breadth Proposal #1: Architectural.....	11
Breadth Proposal #2: Acoustical	11
Schedule.....	Error! Bookmark not defined.

Executive Summary

The following proposal includes the work to be completed in the spring 2011 semester for AE 482 – Architectural Engineering Senior Thesis. The spring thesis requirements are to complete two depth subjects of lighting and electrical along with two breadth subjects.

The first depth topic, lighting, will be a complete redesign of the lighting systems and controls of four different spaces within the Virginia Advanced Shipbuilding and Carrier Integration Center.

The second depth topic, electrical, includes a redesign of panelboard sizes for the four lighting spaces, a protective device coordination study addressing a single-path through the distribution system, and a short circuit calculations for design changes.

The two breadth topics being proposed are an exterior landscape design of a gathering space and an acoustical study in response to a material and contour change of the auditorium ceiling. Also, mechanical diffusers will also be addressed having an effect on the acoustics of the space.

Background

The Virginia Advanced Shipbuilding and Carrier Integration Center (VASCIC) is a shipbuilding facility comprised of two buildings, the Office Tower and Laboratory Wing, totaling approximately 241,000 square feet. It is located in Newport News, Virginia along the James River and 24th Street. VASCIC is the leading researcher in nuclear-powered aircraft carriers while enhancing the quality and competitiveness of the shipbuilding industry. In the seven-story Office Tower is where the new technologies for shipbuilding is researched and in the three-story Laboratory Wing is where testing and actual constructed is conducted. The entire facility was designed and constructed by Clark Nexsen Architecture and Engineering firm from December 1999 to February 2002.

The architecture for the VASCIC facility was completely inspired by ships and shipbuilding which also influenced the proposed lighting design throughout the facility. Being dictated by water, the proposed lighting design is planned to achieve a liquid and free flowing, as well as fluid and dynamic concept.

The four spaces that are to be studied as a part of this thesis study are the lobby and atrium, an open office space, the auditorium, and the exterior gathering space. Each of these spaces is described in further details within the following report. Floor plans and views are provided for further understanding.

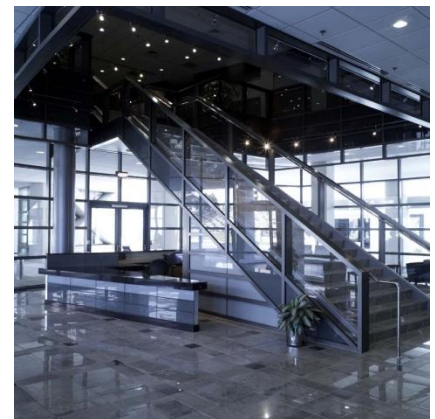
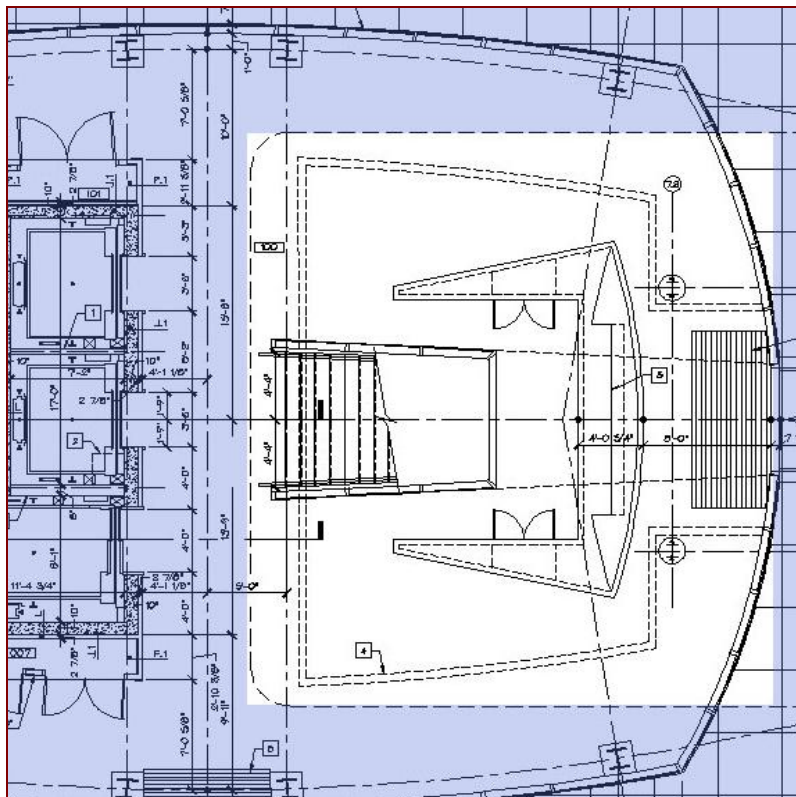

Figure 1: Floor plan and photo of Lobby/Atrium Space

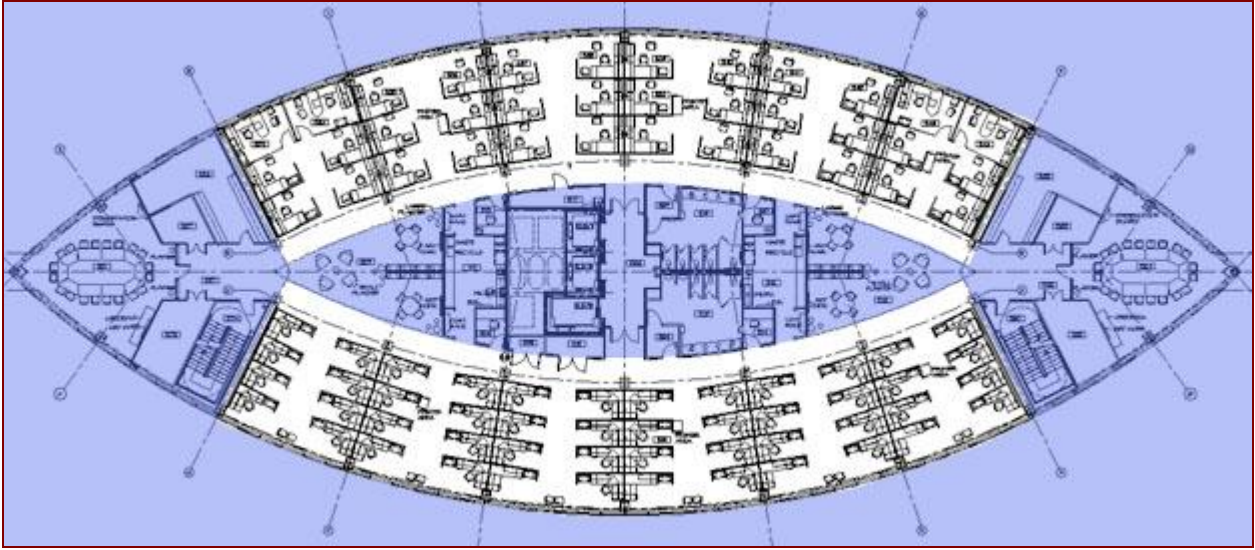

Figure 2: Second through sixth floor open office floor plan

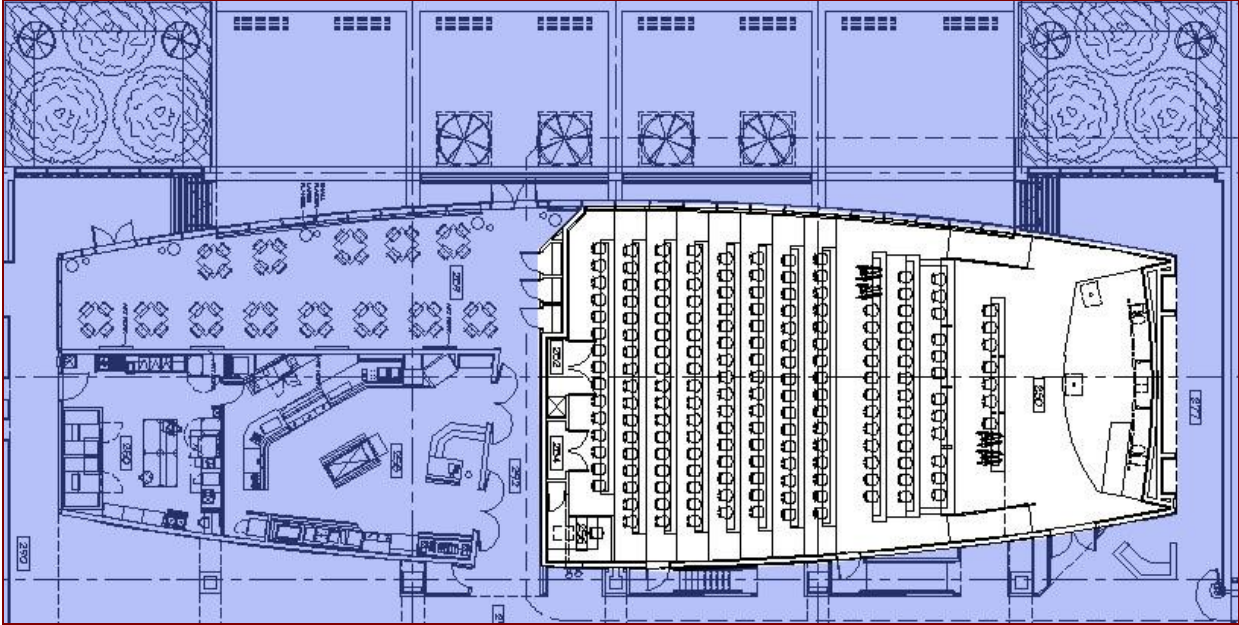

Figure 3: Auditorium floor plan

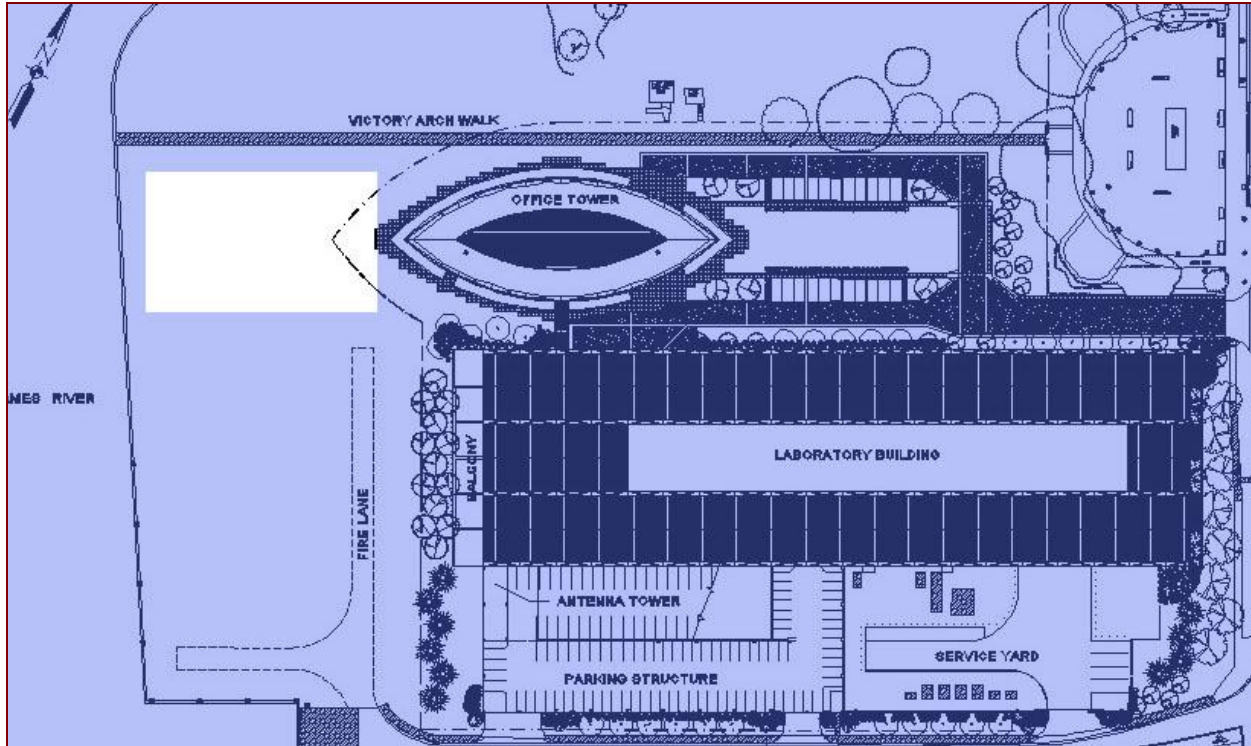

Figure 4: Exterior gathering space proposed design site

Lighting Depth

Overview

The scope of the lighting re-design includes the lighting design for the above mentioned spaces to be completed in the spring 2011 semester. Computer programs, such as AGI32, AutoCAD, and Autodesk 3D StudioMax will be used to investigate lighting equipment, controls, and others to conclude the best solution for design and presentation purposes. The schematic design phase of this re-design was completed for Technical Assignment 3 and presented to a panel of professional lighting designers on December 8th, 2010. Their comments are concluded at the end of this proposal document.

Lobby/Atrium

The lobby/atrium space is the only part of the building located on the ground floor of the Office Tower. It is the central column of circulation throughout the entire Office Tower and therefore needs to present an impressive environment when a visitor first enters. Because the entire façade of the Office Tower is enclosed in glass, daylighting and direct glare will be the driving force when placing light in the space. When doing so, the reception desk and main stair case need to be adequately lit for ease of circulation and safety throughout the space. Also, designing the space to provide enough light for a safe transition from the exterior to interior environment is very important. With that being said, lower light levels may be appropriate for later times of the day

when levels of contrast between environments decrease as well as the times of occupancy in the facility.

Open Office Work Space

The Open Office is located on floors two through six and provides work stations for 80 workers per floor. Work environment is crucial in this space and will employ a task/ambient approach for design. It is also important to consider the glazing surrounding the workers to not create glare on surfaces throughout the space. Highlighting vertical elements will provide a more spacious environment as well as highlighting surrounding walls and ceiling. This space will likely be lit using indirect pendants utilizing a small direct component for the addition of ambient lighting, individual task lights at each work station for personal control, and wall sconces to provide additional lighting for the interior corridor while emphasizing the vertical elements creating a more spacious work environment.

Auditorium

The Auditorium space provides seating for 180 people and is primarily used for presentations and meetings. It is important to provide adequate lighting on the stair and walk way areas, desk surfaces, and highlight the speaker podium while not producing glare on the projection screen. In addition, the auditorium is constructed with a curtain wall system on the north-west wall. It is important to consider this feature for control purposes in the space.

During the schematic design process, three lighting designs were developed for this space. The first concept, "Pools of Light", utilized downlighting throughout the space to literally place pools of light on the surfaces of the space. The second concept, "Uniform Flow", utilized the technique of washing the surrounding surfaces as well as desk surfaces to highlight the task surface and walkway areas. The third concept, "The Ripple Effect", employed a redesign of the ceiling to mimic the fluid motion of a wave in combination with curved, luminous panels to add visual interest and luminosity to the ceiling. Wall washing and downlights were used for ambient and task lighting in the space.

A combination of each design will be employed for the final design, pushing forward most with the newly designed ceiling to add visual interest and excitement to the space. Recessed LED step lights will be used to illuminate stair and walk ways appropriately and integrated linear fixture for task lighting in the desks will be utilized.

Exterior Gathering Space

In the exterior gathering space, a combination of existing and newly designed architectural features is designed for lighting. The existing architecture contains the Victory Arch and Victory Walk located on the north end of the site, and the new architectural features were designed directly behind the Office Tower along the James River. The two existing features were designed to commemorate WWII veterans; however lighting was not designed for these spaces nor did they project an image of importance. The additional exterior space was designed primarily for the community to enjoy as well as enforcing the importance of the Victory Arch in connection with the surrounding water while projecting a psychological impression of festive.

As mentioned before, shipbuilding and water are the driving forces of design for this facility architecturally and from a lighting standpoint. Along the Victory Walkway, the idea of educating the community and visitors about what the VASCIC complex achieves is the main idea. Designed around the evolution of aircraft carriers, the Victory Walkway would display information and history about nuclear-powered aircraft carriers highlighting the importance of the Victory Arch as well as the VASCIC facility.

The new pathway directly behind the Office Tower will also tie into the influential component of water. The design of the meandering pathway will be designed in an imitating fashion of the wake behind a ship. Within this pathway would be covered seating areas as well as curved benches along the path and interacting water features. Contrasting levels of lighting throughout the pathway will be employed to create points of interest throughout the journey to the waterfront.

When designing the lighting for both spaces, many considerations were accounted for. Security and pathway illumination are the most important to make the user feel safe as well as circulation through the space easily. Also controls will play an important part, such that they will require different levels of illumination for day and night.

All of the schematic lighting designs researched in Technical Assignment 3 would be achieved by uplighting the Victory Arch, two flag poles, and landscaping to create a dramatic feel to the space. General illumination for safety and vertical rendering purposes would be achieved by a type of pole mounted fixture with full cutoff in order to not produce light pollution. Within the seating areas of the new design, integrated under-lighting of the curved benches would be used and low-leveled downlighting would be utilized for the covered seating areas highlighting the structures dramatically. In-grade lighting would be added for pathway illumination as well as landscape lighting along the path for added expression of the space. In-grade, water proof LEDs would be employed for the color changing fountains.

Designer Comments from Lutron Presentations (08 December 2010)

Mike Barber

General

- Well spoken
- Consistency throughout spaces and presentation
- Develop design criteria based on considerations of space
- Well thought out ideas were helpful

Multi-Purpose Space

- Daylighting integration study should be done to see impact during occupancy hours of 8am to 5pm.
- “Pools of Light” was a cool idea.
- Interactive stair feature was cool but a bit over the top.

Open Office Space

- How does clear and fritted glass affect building appearance from exterior?

Lobby/Atrium

- Daylighting should be looking at to see how much electric light is needed for the rest of the space.
- Contrast ratios within space were lost.
- Accessibility.

Exterior Gathering Space

- “Killer idea”.
- Strong link between concept and design: water.
- Think about lighting for vertical rendering (faces).
- Too many layers of light within design, make points of interest by having areas of higher and lower illuminances.
- Interactive fountains were confined. Perhaps break the rigid flow and add freedom to the fountains by creating an interactive water feature.

Lee Brandt

Multi-Purpose Space

- Incorporate shading systems for control of daylight.
- Second and third schematic both employ wall washing, whereas the first schematic adds general lighting utilizing downlights which could potentially be very shadowy.
- Second schematic needs to show more defined ceiling wash.
- Third schematic with glowing ceiling may be enough illumination for task lighting and would not need pendants.
- Change color of ceiling from blue to white during presentation time to avoid unwanted color rendering appearances.

Open Office Space

- Play architect, redesign workstations to avoid using partitions so occupants can enjoy the beautiful exterior glazing the building was designed for.
- Check energy code, probably will not need the addition lighting for vertical highlights in office area.
- Different pendant sizes may be distracting, think about using a pendant that mimics the shape of the building rather than a round shape.

Lobby/Atrium

- May be too many layers of light, will only need one source to illuminate stairs.

Exterior Gathering Space

- Make sure to emphasize “public” space in presentation.
- Too many layers of light.
- Arch lighting may need more uplighting to appear more even at middle cornice.

Luke Tigue

General

- Make transition slides all one format.
- Pertaining to existing examples of what design is trying to employ: show what you want them to see, not another example.

Multi-Purpose Space

- Schematic three was strongest and provides more options.
- Other schematics created too much uniformity and lost concept within space.
- Define problems within space and how you propose to solve them.

Open Office

- Perspective showed space but was not a large enough viewport, what happens at joining of walls and furniture layouts within space.

Lobby/Atrium

- Strongest space.
- Glowing front reception desk was good.
- Stairs were illuminated well.

- Be careful in presenting visually what you are trying to show, watch color choice if it is not supposed to be a different color, do not distract the viewer by providing a miss perceived visual.

Electrical Depth

The scope of the electrical re-design portion of this proposal coincides with the new lighting design for the four spaces addressed in the lighting portion of this thesis research. In these four spaces, the re-design of the branch circuit distribution as well as conducting a protective device coordination study will be performed. The depth topics I will be researching are the comparisons between bus ducts and conduit with wires as well as the design of a motor control center both located in the Laboratory Wing of the VASCIC facility.

Re-Design of Four Spaces

Lobby/Atrium | Ground Floor

Visitors and employees of the VASCIC facility will enter through the main lobby on the ground floor of the Office Tower. The existing lighting equipment of the space includes incandescent and halogen track lighting fixtures and recessed downlights utilizing compact fluorescent and metal halide sources. The track lighting system was designed to highlight the atrium opening as well as highlighting the technology display at the top of the stair case located on the second floor. The proposed lighting design will achieve lower energy consumption.

Open Office Work Space | Floors 2-6

Employees of the VASCIC facility need to be in a spacious, well light work environment to promote productivity. This space employs a shading system along the curtain wall enclosure; however this defeats the purpose of providing an environment with exterior views. Different types of fritted glass will be explored to reduce the glare from daylight while utilizing the advantages of providing ambient natural light. A shading system will also be investigated for this space; however it will be designed to have little effect on the exterior appearance of the building. Linear fluorescent indirect fixtures are currently used to achieve a task/ambient approach. The proposed lighting design will achieve lower energy consumption while enhancing the work environment for the VASCIC employees.

Auditorium | Second Floor Laboratory Wing

The 180 seat auditorium is a multi-purpose space used primarily for presentations and meetings. With controllability driving the lighting design, multiple scenes are necessary to achieve the needs of the space. There are currently five different source types within the space, including compact and linear fluorescents, as well as incandescent floor lamps. In addition, there is a curtain wall system on the north-west wall of the auditorium that currently employs shading devices. Further research into different solutions for this problem will be performed as well as reducing the energy consumption of the space while achieving the necessary controllability.

Exterior Gathering Space | Site behind Office Tower

The exterior gathering space currently is only designed for the Victory Walkway. I am proposing to produce an interesting and exciting environment to the community behind the VASCIC facility as well as integrating the existing conditions. The lighting employed for the Victory Walkway is metal halide bollards. The proposed lighting design will achieve lower energy consumption in addition to the new exterior gathering space.

Protective Device Coordination Study and Short Circuit Analysis

A protective device coordination study will be conducted addressing a single-path configuration through the distribution system extending to one of the switchboards TSB, SBPA, SBPB, or SBPC. The coordination of protective devices from the redesigned system components along this path will be provided along with short circuit calculations.

Depth Topic 1 | Bus Duct vs. Conduit and Wires

A comparison study will be performed in order to determine the most cost effective way to supply power over long distances. The problem will address the long runs of conduit in addition to the amount of wires needed to supply the panels in the Laboratory Wing. An analysis of the conduit and wire size compared to the existing eight bus ducts will be performed to conclude the most cost and energy effective solution.

Depth Topic 2 | Motor Control Center Design

A comparison study will be performed in order to determine an efficient way for maintenance purposes of the six air handling units for the VASCIC facility. Four units are located on top of the Laboratory Wing and two are located in the Penthouse on the roof of the Office Tower. Providing one location for the air handling units to be serviced is a convenient solution. The motor control center will be located within the Laboratory Wing in the research portion of the facility. This is the most logical location for the motor control center because it is a three story open space. The use of this space will need to be better understood to not disturb any other operations within the space.

Breadth Proposal #1: Architectural

As mentioned earlier, an architectural design of an exterior gathering space will be refined, as preliminary designs have been made during the schematic design phase of Technical Assignment 3. The final design for the space will employ all the design concepts of the architecture as well as the lighting design while employing a safe and exciting environment for the employees and community to use.

Breadth Proposal #2: Acoustical

Because I am proposing to redesign the ceiling in the auditorium, it is necessary to study further how this will affect the acoustics of the space as there will be audio systems used for presentations and meetings. The new acrylic panels will reflect sound waves differently than regular acoustical ceiling tiles. Also the mechanical system will need to be studied to reassure there are no other contributing noise factors within the space.

